

CUSTOMER DRAWING

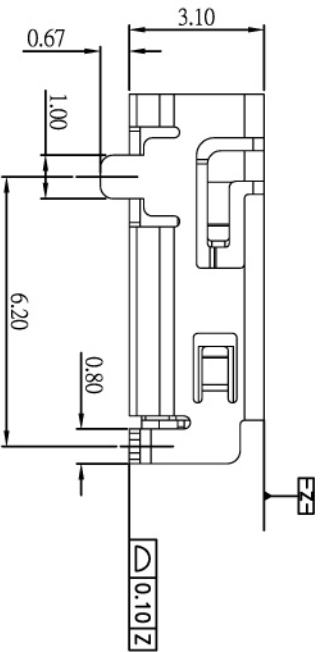
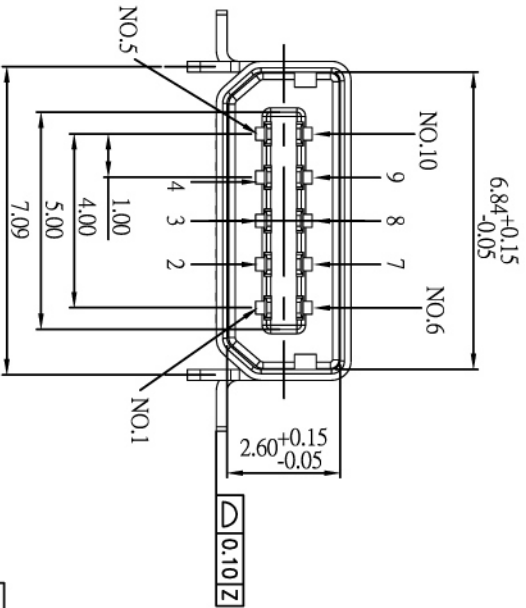
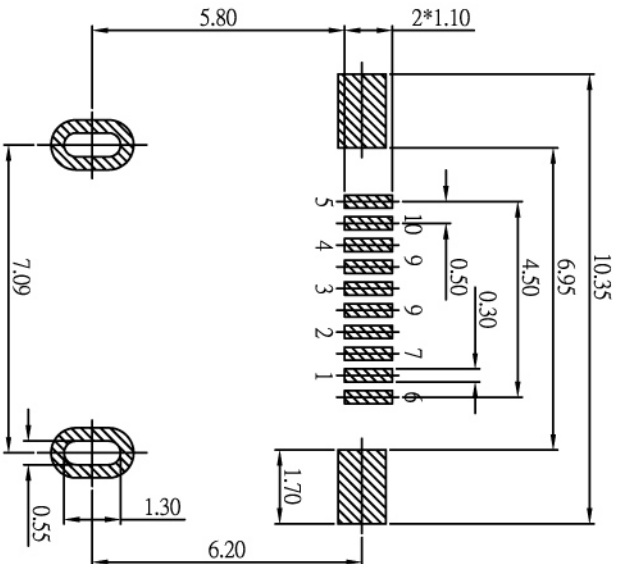
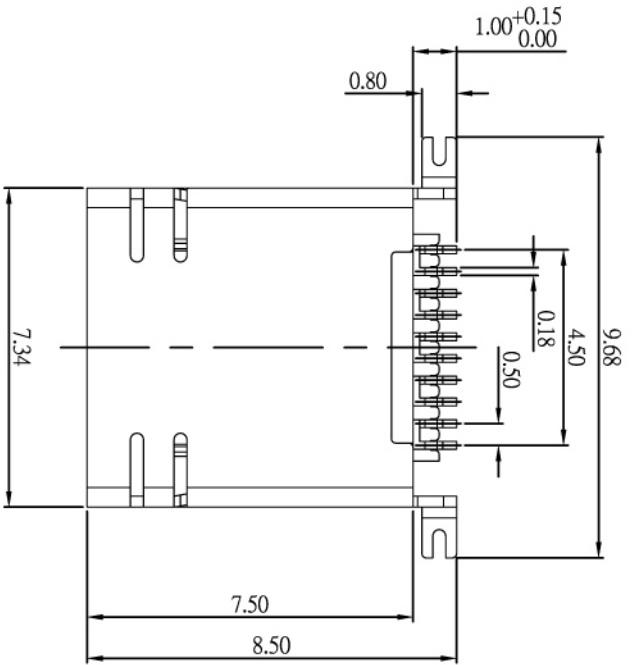

RECOMMENDED P.C.B. LAYOUT
TOLERANCE:±0.05 TOP VIEW

| NO. | PARTS | QTY | |
|-----|-------------|-----|--|
| 1 | Housing | 1 | PA9T (UL94-V0).BLACK |
| 2 | Contact Pin | 5 | C5191-EH T=0.15 UNDER PLATED 50u" MIN. NICKEL OVER ALL 3u" GOLD OVER ALL, 15u" GOLD PLATED IN CONTACT AREA |
| 3 | Contact Pin | 5 | C5191-EH T=0.15 UNDER PLATED 50u" MIN. NICKEL OVER ALL 3u" GOLD OVER ALL, 15u" GOLD PLATED IN CONTACT AREA |
| 4 | Shell Cover | 1 | C5191-EH T=0.25 Tin 120u" OVERALL. |

2.PACKAGE: TAPE REEL
3.COPLANARITY:0.1MAX

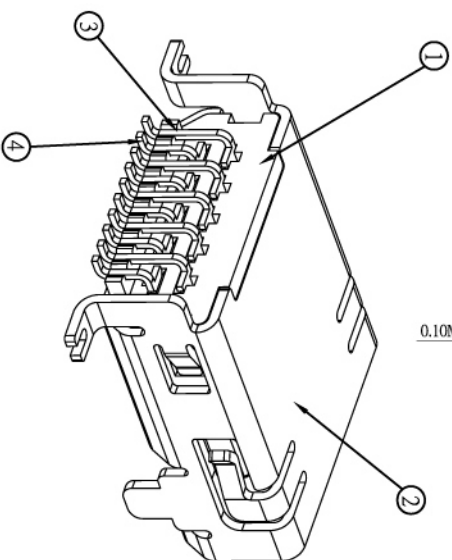
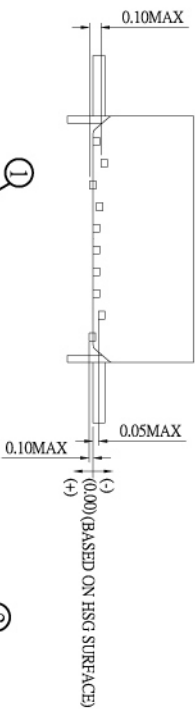

| REV. | REV. DATE | REV. BY | REV. REASON |
|------|-----------|---------|-------------|
| A3 | 05/11/12 | James | 修改者 核准 |
| A2 | 05/11/12 | James | 取消助條 |
| A1 | 06/01/11 | James | 取消凸條 |
| A0 | 05/11/23 | James | 修改公差 |

| | | | | | | | | | |
|---------|--------------------------------|----------|-----------|------|----|------|--------|-----------|----|
| 圖號 | GC020001 | 材質 | Alan Chao | 單位 | mm | 頁碼 | 1 of 1 | 圖紙尺寸 | A4 |
| DWG NO. | KS020103 | MATERIAL | | DR | | PAGE | | DRAW SIZE | |
| 料號 | | | | 審核 | | | | | |
| 品名 | EAR MIC CONNECTOR 10PIN SMD型母座 | | | 核准 | | | | | |
| TITLE | | | | DATE | | | | | |

TC-TEK Industries Limited



REV: A3

