

RECOMMENDED P.C.B. LAYOUT
TOLERANCE: ±0.05 TOP VIEW

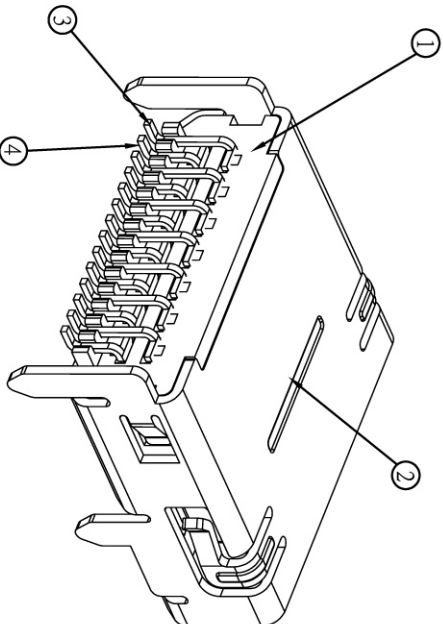
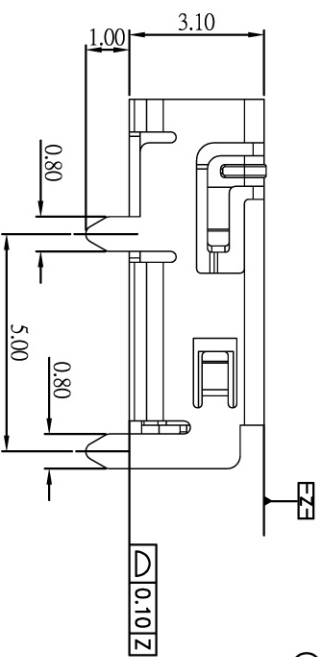
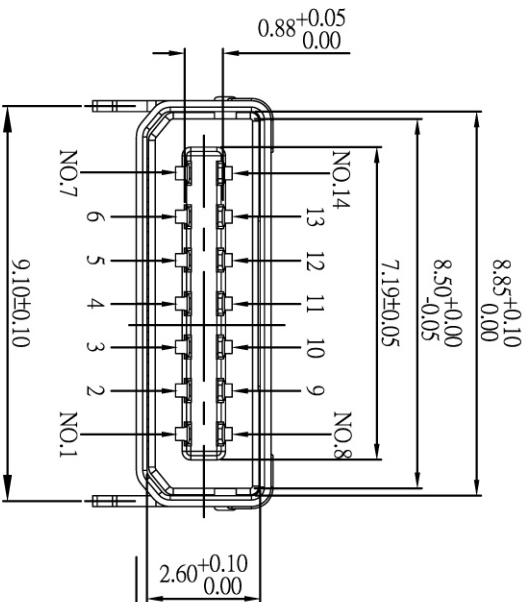

NO.	PARTS	QTY	
1	Housing	1	PA97 (UL94-V0);BLACK
2	Contact Pin	6	C2680-EH T=0.15 UNDER PLATED 120u" MIN. NICKEL OVER ALL. 3u" GOLD OVER ALL, 15u" GOLD PLATED IN CONTACT AREA
3	Contact Pin	6	C2680-EH T=0.15 UNDER PLATED 120u" MIN. NICKEL OVER ALL. 3u" GOLD OVER ALL, 15u" GOLD PLATED IN CONTACT AREA
4	Shell Cover	1	C5191-EH T=0.25 Tin 120u" OVERALL.

2.PACKAGE: TAPE REEL

圖號 DWG NO.	材料 MATERIAL	繪圖 DR	單位 UNITS	比例 SCALE	日期 DATE	頁碼 PAGE	1 OF 1	圖紙尺寸 DRAW SIZE	A4
KD023203		審核 CHKD	m/m	1 : 1	2005/08/25	TC-TEK		台灣研科實業有限公司 TC-TEK Industries Limited	
品名 TITLE	EAR MIC 14PIN Connector DIP TYPE H=1.0mm	核准 APRO				REV:			1

字號	說明	日期	修改者	核准
X.	±0.1	X.	±2°	
X.X	±0.08	X.X	±1°	
X.XX	±0.05	X.XX	±0.5°	



REV: 1

F

E

D

C

B

A

1

2

3

4

5

6

7

8